



LARSSON

LARSSON

SUZHOU LARSSON ELEVATOR CO.,LTD

Headquarters:
No.11 Qinglian RD, Xuguan Development Zone,
Suzhou, Jiangsu, China, 215151
E-mail: info@elevatorschina.com
Tel: +86 512 6618 1118
Fax: +86 512 6959 1223
Website: <http://www.ElevatorsChina.com>

All the information in this catalogue is only for reference. LARSSON Elevator reserves the right to alter product design and specification. Specifications subject to change without notice.
Printed in June, 2014

LARSSON

Escalator & Moving Walk



Escalator Summary

LARSSON series escalator & moving walk adopt the advanced international technology for its design and manufacture. It meets the standard of GB16899-97 of Safety rules for the construction and installation. It has the features such as exquisite structures, consummate step, smart railing, pleasing outline model, smooth running, easy maintenance etc. It provides vast passengers with a brand-new feel of brightness and coziness.

It makes the feelings of the extra-ordinary and luxury, which is coming from modern architectures. It is widely applicable in various public places, such as the shopping mall, supermarket, subway, airport, exhibition halls.



Advantageous Performances of Escalator

- The truss utilizes first class angle steel with unique structure, high strength and complete durable features.
- The overall design is concise and smooth and compatible.
- The advanced international craftsmanship ensures the accuracy of steps.
- The large size diameter of step roller with stable running, low noise and long lifetime.
- The human-oriented handrail entrance is secured by brush.
- The skirt panel, inside and outside of cover plate are made of stainless steel.
- Etched stainless steel from panels are available with various patterns.
- The main board of super CPU monitors the operation in real time, which can automatically stop the running and records the error code in case of any abnormal condition happen.
- VVVF is optional for control running speed to save energy. It can prolong the lifetime and operations cost.



Moving Walk summary

LARSSON series escalator & moving walk adopt the advanced international technology for its design and manufacture. It meets the standard of GB16899-97 of Safety rules for the construction and installation. It has the features such as exquisite structures, consummate step, smart railing, pleasing outline model, smooth running, easy maintenance etc. It provides vast passengers with a brand-new feel of brightness and coziness.

It makes the feelings of the extra-ordinary and luxury, which is coming from modern architectures. It is widely applicable in various public places, such as the shopping mall, supermarket, subway, airport, exhibition halls.



Advantageous Performances of Moving Walk

● Compact structure, ease strain

Short pallets can greatly reduce space span, which can flexibly fit the building structure and save the construction space. It comprises H version (horizontal), I version (incline) and C version (compact) can let the customer have a free choice on his original layout.

● Conform to quality / safety standard

Slip-free grooves on pallet surface have an excellent slip-proof function which makes the ride safe and comfortable. Slightly inclined combs can make trolleys easily get on conveyors. Hanson traction machine with complete protecting function runs smoothly and drives efficiently. Advanced microcomputer controlling system can fully monitor the running status of the moving walk.

● Stable and reliable investment

The pallet directly connecting with the chain which makes the running more smoothly and quietly, thus the service life is extended and its maintenance can be easily conducted. Special designed big wheel handrail drive runs in low noise and big power, which improves the running condition of handrail, its life is hence prolonged. Unique angle iron structure has a big load capacity, which greatly improves the overall stability and service life.

● Colorful decoration

Various styled handrail can meet personal demand in different environments. Beautiful stainless steel floor plate has a three-dimension effect. Inner and outer cover plate adopts stainless steel.

● Incomparable economical

The moving walk fully utilizes advanced manufacturing process, greatly improves product performance and service life, the most direct effect is that the operation cost of the customer is reduced. The optional VVVF drive technology yields great energy-saving, reducing the running cost to the maximum.

Illustration of Escalator Main Parts

Escalator Safety Parts



Safety devices of HS200 Escalator

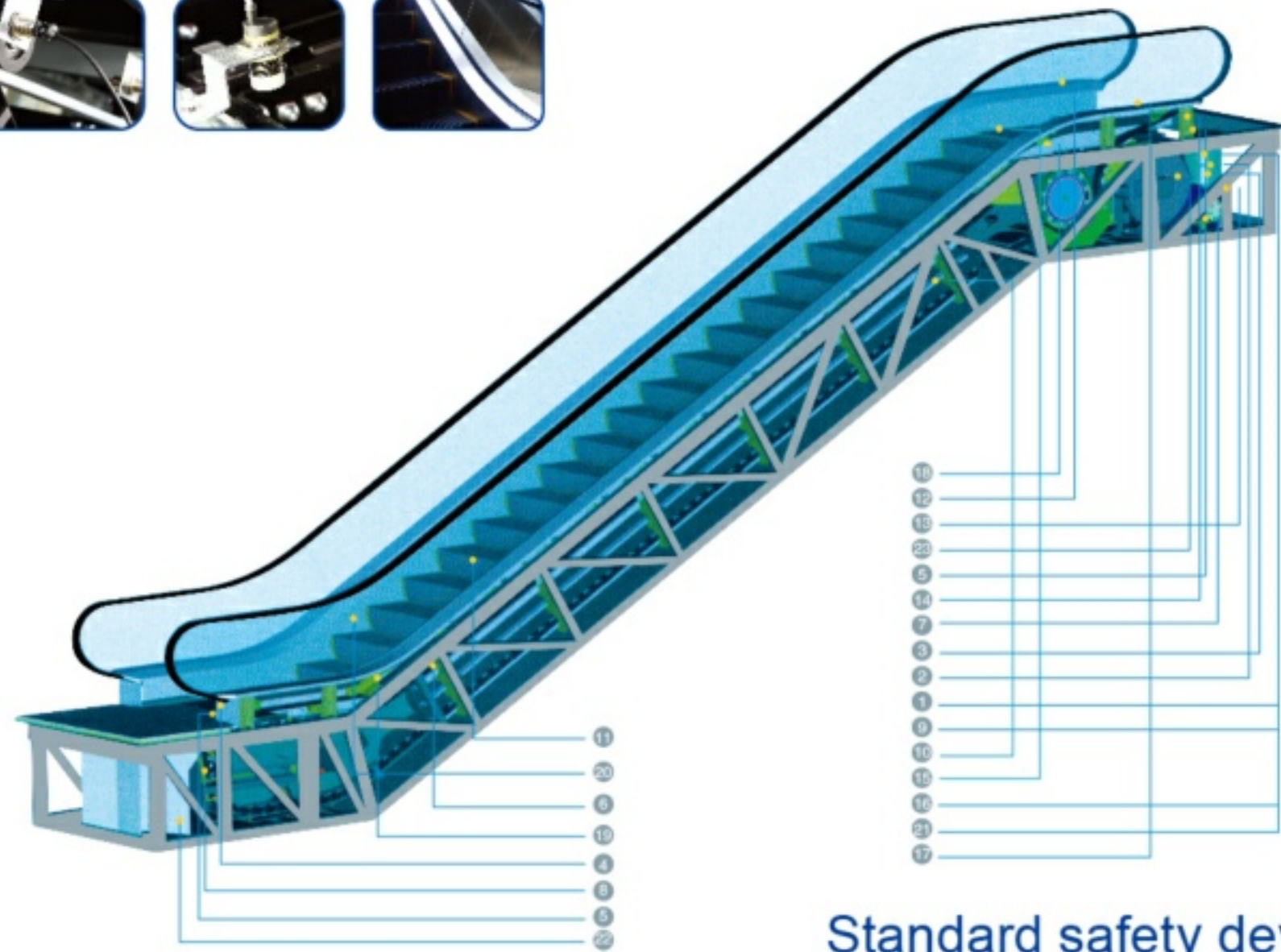

Standard safety device

1. Lack of phase, error phase protection

The escalator (moving walk) will be automatically stopped for running in case of phase failure.

2. Motor over-load protection

The escalator will be automatically stopped running in case the current exceeds the 15% of rated.

3. Electrical appliance loop protection

It offers the automatic circuit disconnecting device to protect the circuit and main components of the escalator (moving walk).

4. Handrail inlet protection

When foreign matters are jamming in the handrail inlet, the escalator (moving walk) will be automatically stopped for running.

5. Comb plate safety device

When foreign matters are jamming in or between the combs, the escalator (moving walk) will be automatically stopped for running.

6. Step sagging protection device

When there is abnormal step bending, the escalator (moving walk) will be stopped for running before the step entering into the comb plate.

7. Broken drive-chain safety device

When the drive-chain has been over-stretched or it is broken, the escalator (moving walk) will be automatically stopped for running.

8. Broken step chain protection

When the step (pallet) chain has been over-stretched or broken, the escalator (moving walk) will be automatically stopped for running.

9. Over-speed protection

When there is over-speed to the escalator (moving walk), it will be automatically stopped for running.

10. Direction reversal protection

When it comes the unintentional reversal of the direction of travel, the escalator (moving walk) will be automatically stopped for running.

11. Security line

The yellow synthetic resin security line is located in the front position and two sides of the escalator step so that the passengers will not step on the edge of the adjacent step or between step and skirt panel. The security line on both sides of the step is higher than the tread surface. (The moving walk offers the selective yellow spray-painted security line.)

12. Emergency stop button

When the button has been pressed down, the escalator (moving walk) will be stopped for running.

13. Brake protection

When the electric force falls short of supply or it acts any of the safety device, the brake function goes into effect by the safety device through the spring resilience action, the escalator (moving walk) stopped for running accordingly.

Safety devices of HS300 Moving Walk

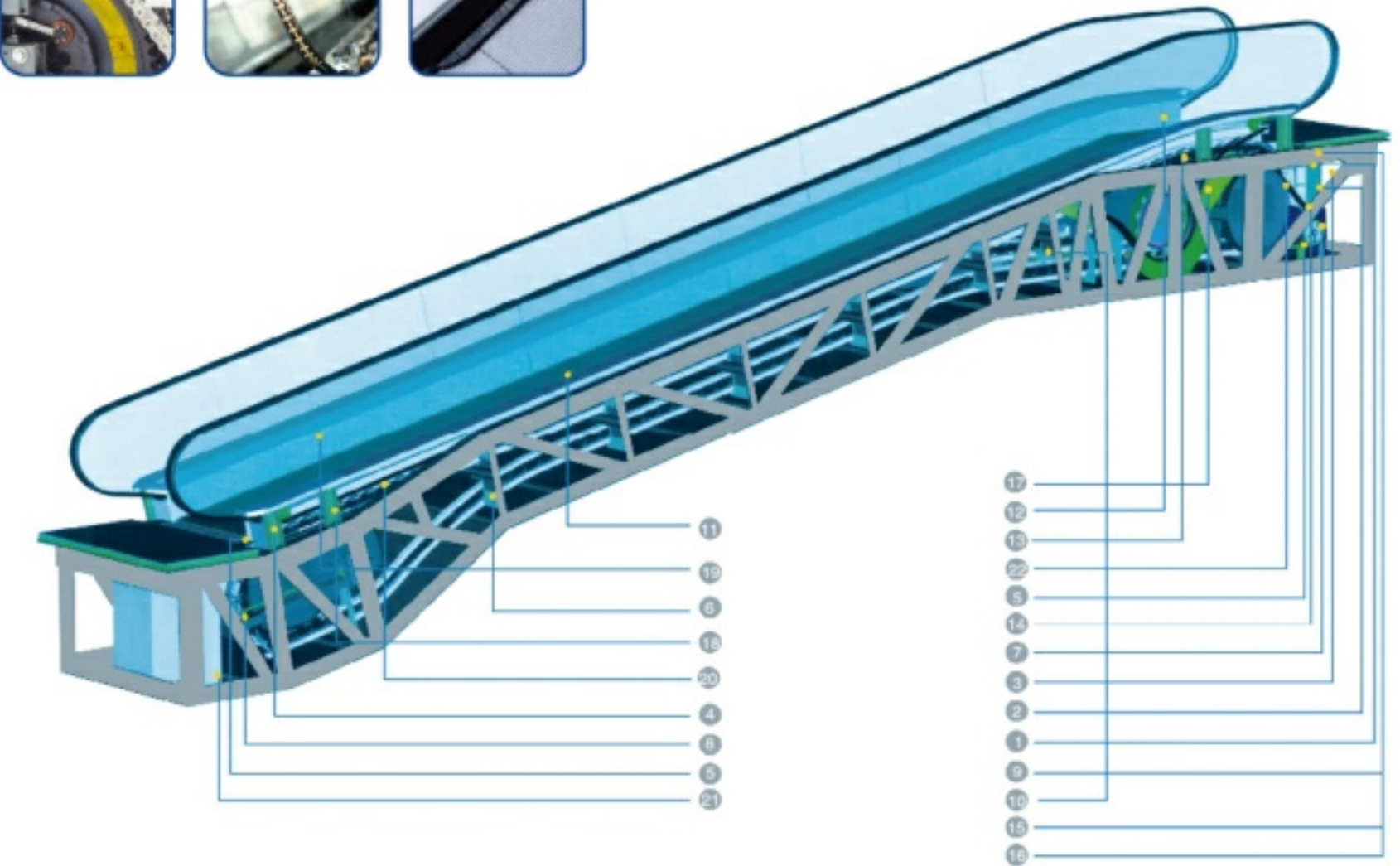

14. Safety inspection switch

It has a safety device to prevent from the escalator starting during the inspection and maintenance.

15. Step illumination

Illumination exists in the upper and lower ends of the escalator, in the lower part of the step in order to remind the passengers of the security matters.

16. Skirt panel protection

When foreign matters has been jammed in between the skirt panel and the step, the escalator (moving walk) will be automatically stopped for running.

Optional safety device

17. Alarm bell starting device

The alarm bell rings when the escalator starts in order to remind the passengers of the security matters.

18. Handrail speed monitor

When the handrail speed versus step is slower than certain percentage, the escalator (moving walk) will be stopped for running.

19. Skirt panel brush

It is a optional safety device. The brush that has been installed between the skirt panel and the step will prevent the shoes of passengers from touching the skirt panel.

20. Control device for handrail breakage

When the handrail is broken, the escalator will be automatically stopped for running.

21. Lower machine room drain

When it exceeds the standard water level in the lower machine room, the automatic drain system will start accordingly. (outdoor type)

22. Auxiliary brake

It prevents from the escalator slide and ensures the passengers security in case of the drive chain breakage or the out-of-order of the brake. (It should be equipped with the emergency brake when H>6m.)

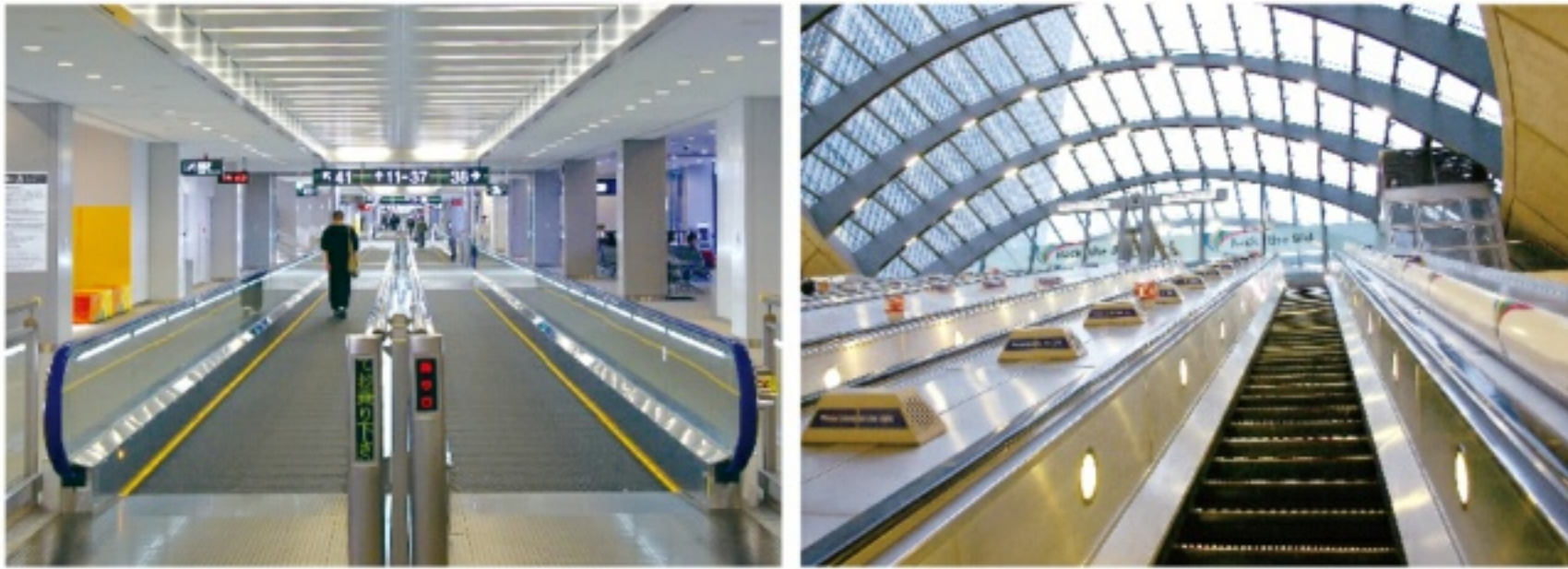

Function

Static electricity protection	Remove static electricity raised from running of steps
Emergency stop button	Push the emergency stop button to stop the escalator / passenger Conveyor against emergency happen
Skirting protection	Protection against risk of foreign matters being jammed into clearance between steps and skirting
Handrail entry safety protection	Protection against risk of foreign matters being jammed into handrail entry
Main drive chains safety protection	Protection against risk of drive chains being breakage or over long
Over-speed protection	Protection against risk of speed being over 20% of rated speed
Under-speed protection	Protection against risk of speed less than 80% of rated speed
Un-intentional reversal protection	Protection against risk of unintentional reversal protection
Lack of phase, error phase protection	Protection against risk of phase failure
Short circuit protection	Protection against risk of short circuit
Over-load protection	Protection against risk of motor continually over-load
Step sagging protection	Protection against risk of steps being breakage and sagging
Step chains safety protection	Protection against risk of step chains being breakage or over long
Comb safety guard	Protection against risk of foreign matters being trapped into comb teeth of step(pallet)

Logical arrangement systematic layout



○ **Single**

Such layout has the advantages of small covering area, flexible escalator arrangement. It can only fulfill one-way intermittent flow of the passengers. It is mostly suitable for small-size shopping places.



○ **Scissored**

Such layout is a bit larger than that from the irregular layout. It can fulfill one-way continuous flow of the passengers. It is mostly suitable for small and medium department stores.



○ **Parallel**

Such layout is mainly fit for large passenger flow shopping centers and public traffic areas. It can fulfill two-way continuous flow of large passenger flows. When one-way peak hour occurs in the passenger flow, we can adjust the travel direction of partial escalators in order to meet the requirements of rush-hour flows requirements. Without an internal retaining plate, such mode is quite economical.



○ **Cross**

Such layout is mainly suitable for large-size department stores and public constructions. The conveying times between these floors shall be minimized as far as possible.

Floor plan of HS200-30K Commercial Escalator

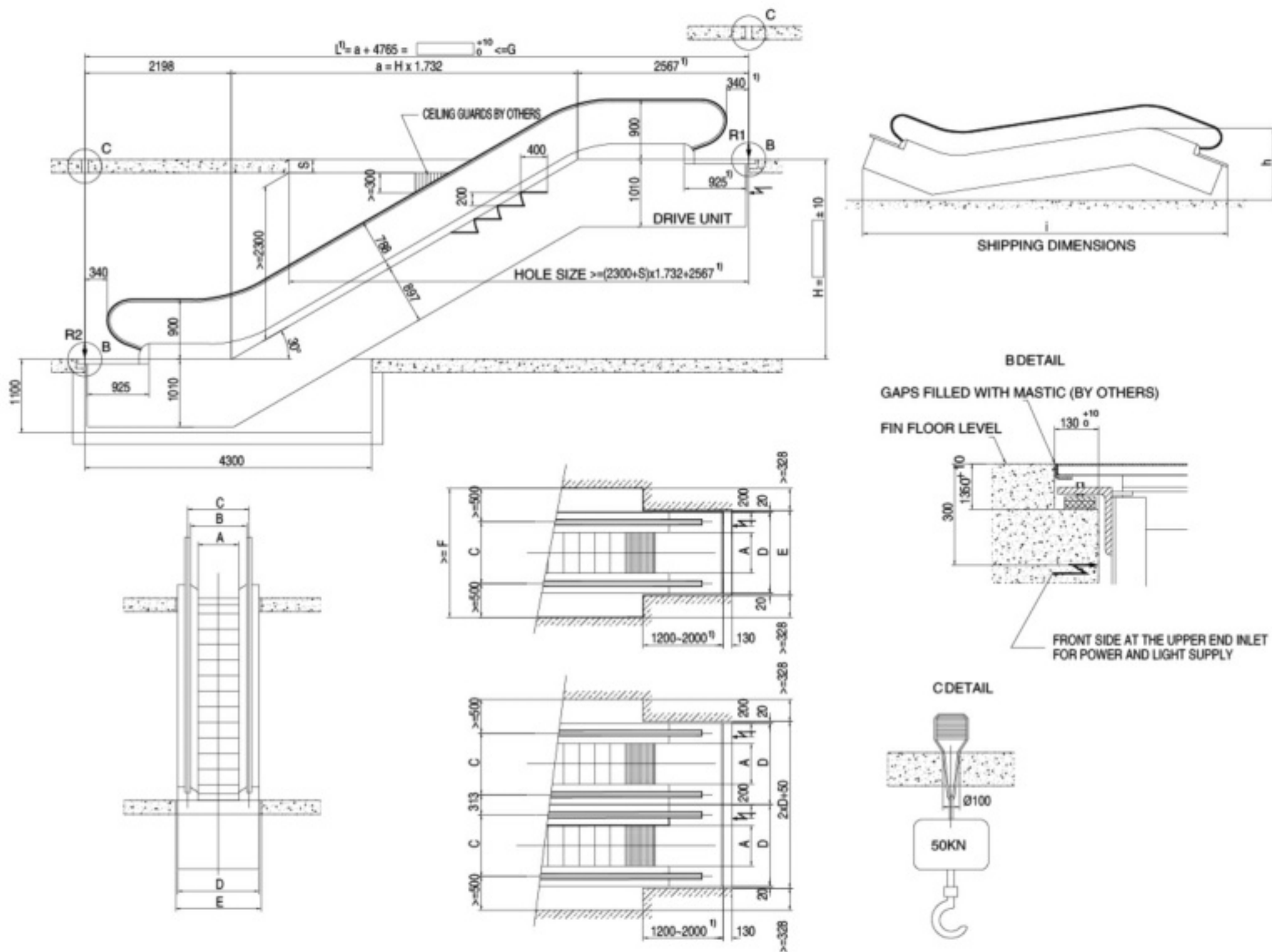

Floor plan of HS200-35K Commercial Escalator

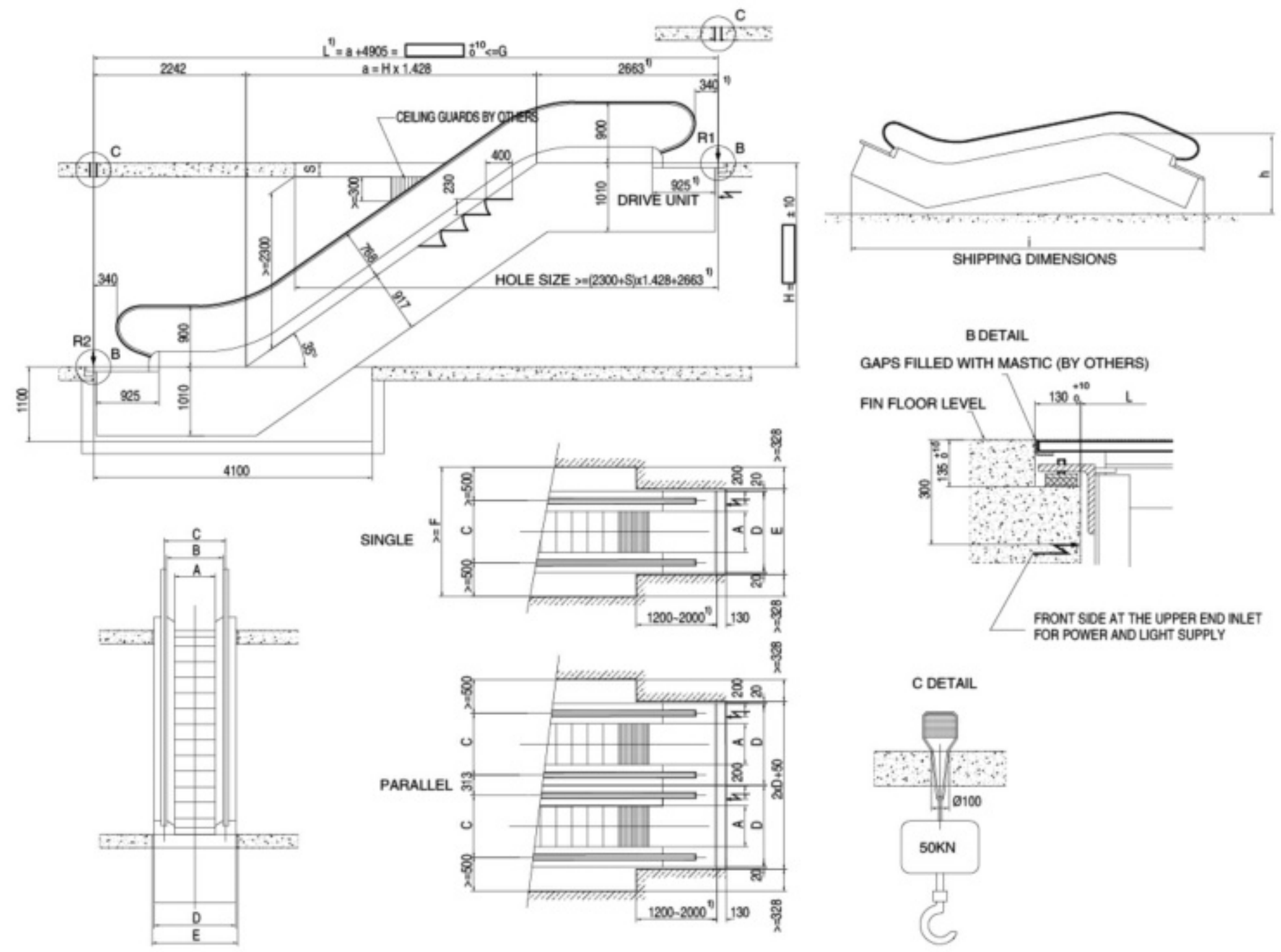

Type	Rise	Weight	Support Loads		Power kw	Transport size	
			R1	R2		H	I
30-60K 4500 man/hour	3000	57	46	41	5.5	2172	11177
	3500	60	49	44		2217	12165
	4000	63	52	47		2254	13155
	4500	67	56	50		2284	14146
	5000	70	59	53		2309	15138
	5500	74	62	56		2330	16131
30-80K 6750 man/hour	3000	59	52	47	8	2348	17125
	3500	63	56	50		2066	10788
	4000	67	60	54		2101	11778
	4500	70	64	57		2130	12769
	5000	74	68	60		2153	13762
	5500	78	74	66		2172	14755
30-100K 9000 man/hour	3000	81	78	69	11	2188	15750
	3500	86	88	79		2201	16745
	4000	71	68	61		2066	10788
	4500	75	73	65		2101	11778
	5000	79	79	71		2130	12769
	5500	83	84	75		2153	13762

mm size units, individual size may be revise

	Step width		
	1000mm	800mm	600mm
A: Step width	1000	800	600
B: Width between handrails	1157	957	757
C: Handrail center distance	1237	1037	837
D: Width of escalator	1540	1340	1140
E: Width of shaft	1580	1380	1180
F: Minimum spacing	2236	2036	1836
G: Maximum outreach	16000	17200	18900

- 1.If L>G, an intermediate support is required, please consult.
- 2.If step width is 600mm, upper truss shall increase 417mm.
- 3.Detailed motor power parameters may check with our technical department.

Type	Rise	Weight	Support Loads		Power kw	Transport size	
			R1	R2		H	I
35-60K 4500 man/hour	3000	54	43	39	5.5	2291	10458
	3500	57	46	41		2345	11309
	4000	60	49	44		2389	12163
	4500	64	52	46		2425	13019
	5000	67	54	49		2456	13877
	5500	70	57	51		2481	14737
35-80K 6750 man/hour	3000	73	60	54	8	2503	15598
	3500	56	49	44		2177	10073
	4000	63	56	50		2253	11782
	4500	66	59	53		2281	12640
	5000	70	62	56		2304	13500
	5500	73	65	59		2324	14362
35-100K 9000 man/hour	3000	76	69	61	11	2340	15224
	3500	60	56	50		2177	10073
	4000	64	60	53		2219	10926
	4500	67	64	57		2253	11782
	5000	71	67	60		2281	12640
	5500	74	71	67		2304	13500

mm size units, individual size may be revise

	Step width		
	1000mm	800mm	600mm
A: Step width	1000	800	600
B: Width between handrails	1157	957	757
C: Handrail center distance	1237	1037	837
D: Width of escalator	1540	1340	1140
E: Width of shaft	1580	1380	1180
F: Minimum spacing	2236	2036	1836
G: Maximum outreach	16000	17200	18900

- 1.If L>G, an intermediate support is required, please consult.
- 2.If step width is 600mm, upper truss shall increase 417mm.
- 3.Detailed motor power parameters may check with our technical department.

The Construction Layout Drawing of HS200 Medium Height Commercial Escalator

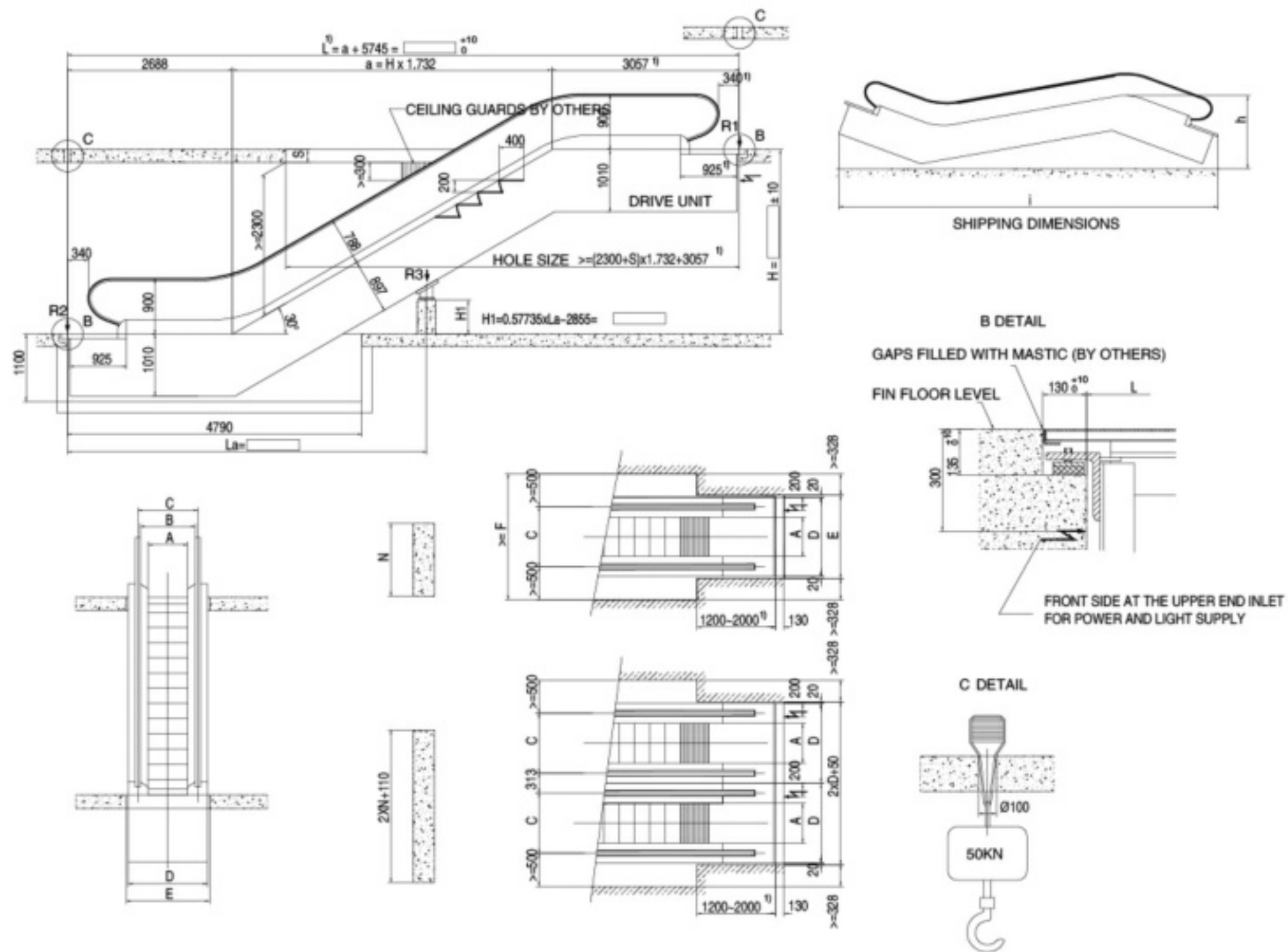

Type	Rise	Weight	Power kw
30-80M 6750 man/hour	H	KN	V=0.5m/s
	6000	89	11
	6500	95	
	7000	99	
	7500	102	15
	8000	106	
	8500	115	
	9000	118	2 x 8
	9500	122	
	10000	126	
30-100M 9000 man/hour	6000	94	15
	6500	100	
	7000	104	
	7500	113	
	8000	117	2 x 8
	8500	121	
	9000	125	2 x 11
9500	129		
10000	133		

mm size units, individual size may be revise

	Step width	
	1000mm	800mm
A: Step width	1000	800
B: Width between handrails	1157	957
C: Handrail center distance	1237	1037
D: Width of escalator	1540	1340
E: Width of shaft	1580	1380
F: Minimum spacing	2226	2036
G: Maximum outreach	16000	17200
N: Width of supporting	1500	1300

- If L>G, an intermediate support is required, please consult.
- With a double drive and Step width of 600mm, the truss must be extended by 417mm.
- Detailed motor power parameters may check with our technical department.

The Construction Layout Drawing of HS200 Public Traffic Type Stainless Steel Slant Handrail Escalator

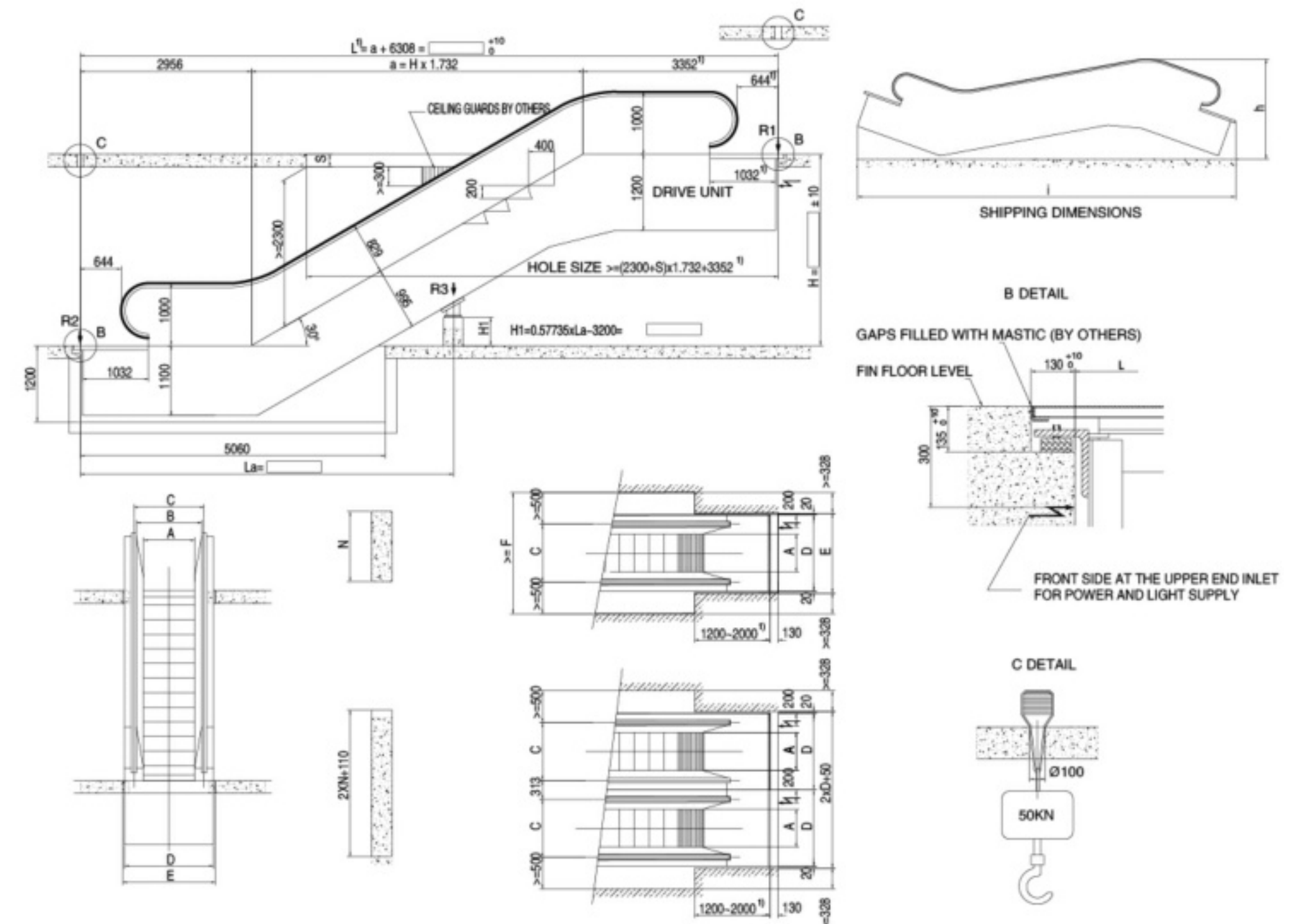

Type	Rise	Weight	Power (kw)		Type	Rise	Weight	Power (kw)	
			V=0.5m/s	V=0.65m/s				Type	Rise
30-80M 6750man/hour	3000	80	8Kw	8Kw	30-100M 9000man/hour	3000	85	8Kw	11Kw
	3500	85	8Kw	8Kw		3500	89	8Kw	11Kw
	4000	89	8Kw	11Kw		4000	93	11Kw	11Kw
	4500	92	8Kw	11Kw		4500	97	11Kw	11Kw
	5000	96	11Kw	11Kw		5000	101	11Kw	15Kw
	5500	100	11Kw	11Kw		5500	106	11Kw	15Kw
	6000	103	11Kw	15Kw		6000	109	15Kw	15Kw
	6500	110	11Kw	15Kw		6500	115/120	15Kw	2*8Kw
	7000	114	11Kw	15Kw		7000	119/124	15Kw	2*8Kw
	7500	117	15Kw	15Kw		7500	129	2*8Kw	2*11Kw
	8000	121/127	15Kw	2*8Kw		8000	133	2*8Kw	2*11Kw
	8500	131	2*8Kw	2*8Kw		8500	137	2*8Kw	2*11Kw
	9000	134	2*8Kw	2*11Kw		9000	141	2*8Kw	2*15Kw
	9500	138	2*8Kw	2*11Kw		9500	145	2*11Kw	2*15Kw
	10000	142	2*8Kw	2*11Kw		10000	150	2*11Kw	2*15Kw
	11000	150	2*8Kw	2*15Kw		11000	158	2*11Kw	2*15Kw
12000	157	2*11Kw	2*15Kw	12000	166	2*15Kw	2*15Kw		
13000	165	2*11Kw	2*15Kw	13000	175	2*15Kw	2*15Kw		
14000	173	2*15Kw	2*15Kw	14000	183	2*15Kw	2*15Kw		
15000	180	2*15Kw	2*15Kw	15000	192	2*15Kw	2*15Kw		
16000	189	2*15Kw	2*15Kw	16000	200	2*15Kw	2*15Kw		

mm size units, individual size may be revise

	Step width		
	1000mm	800mm	600mm
A: Step width	1000	800	600
B: Width between handrails	1157	957	757
C: Handrail center distance	1237	1037	837
D: Width of escalator	1570	1370	1170
E: Width of shaft	1610	1410	1210
F: Minimum spacing	2226	2036	1836
G: Maximum outreach	16000	17200	18900
N: Width of supporting	1500	1300	1100

- If L>G, an intermediate support is required, please consult.
- With a double drive and Step width of 600mm, the truss must be extended by 417mm.
- Detailed motor power parameters may check with our technical department.

HS300-I Moving Walk Layout drawing (10° ~ 12°)

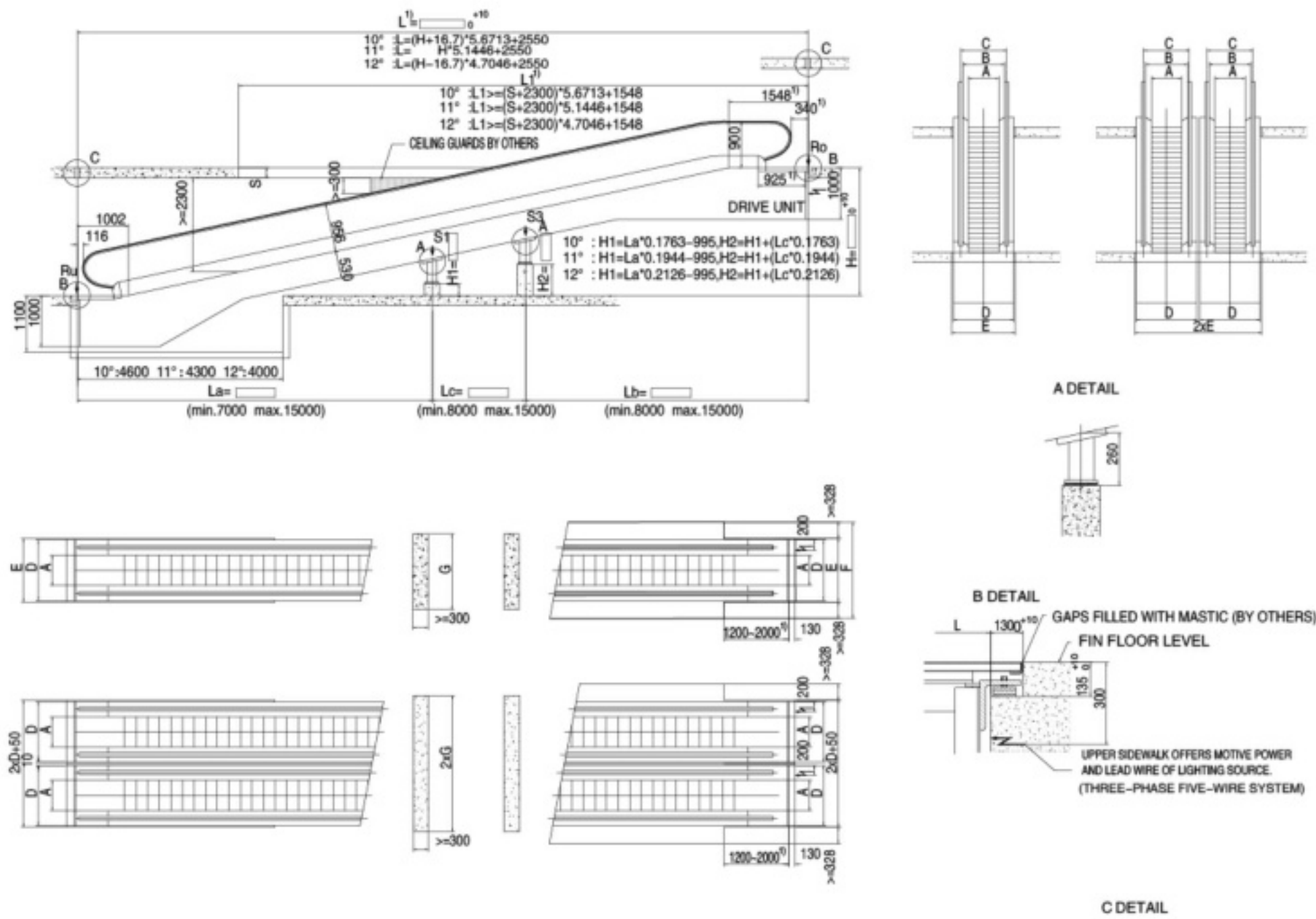

Support					
Without mid-support	Single mid-support		Double mid-supports		
$R_o = L \cdot q + M$	$R_o = L_b \cdot q + M$	$R_o = L_b \cdot q + M$			
	$R_u = L_a \cdot q + N$	$R_u = L_a \cdot q + N$			
$R_u = L \cdot q + N$	$S_1 = (L_a + L_b) \cdot q \cdot 1.3$		$S_1 = (L_a + L_c) \cdot q \cdot 1.3$		
			$S_2 = (L_b + L_c) \cdot q \cdot 1.3$		

Supported by force	q	M	N
YSS80	0.0039	9.5	4.5
YSS100	0.0045	11	5

	YSS80	YSS100
A	800	1000
B	957	1157
C	1037	1237
D	1340	1540
E	1380	1580
F	2036	2236
G	1300	1500

1. Use the tread with 133mm pitch.
2. Upper truss shall increase 417mm for double-drive.
3. Detailed motor power parameters may check with our technical department.

Tilt angle	Rise		Mid-support		La	Lb	Lc
	Min	Max	S1	S2			
10°	1273	2154	-	-	-	-	-
	2155	3388	1	-	7000	L-7000	-
	3389	4799	1	-	L-15000	15000	-
	4800	6000	1	1	7000	15000	L-22000
11°	1423	2394	-	-	-	-	-
	2395	3754	1	-	7000	L-7000	-
	3755	5309	1	-	L-15000	15000	-
	5310	6000	1	1	7000	15000	L-22000
12°	1572	2634	-	-	-	-	-
	2635	4122	1	-	7000	L-7000	-
	4123	5822	1	-	L-15000	15000	-
	5823	6000	1	1	7000	15000	L-22000

HS300-II Moving Walk Layout drawing (10° ~ 12°)

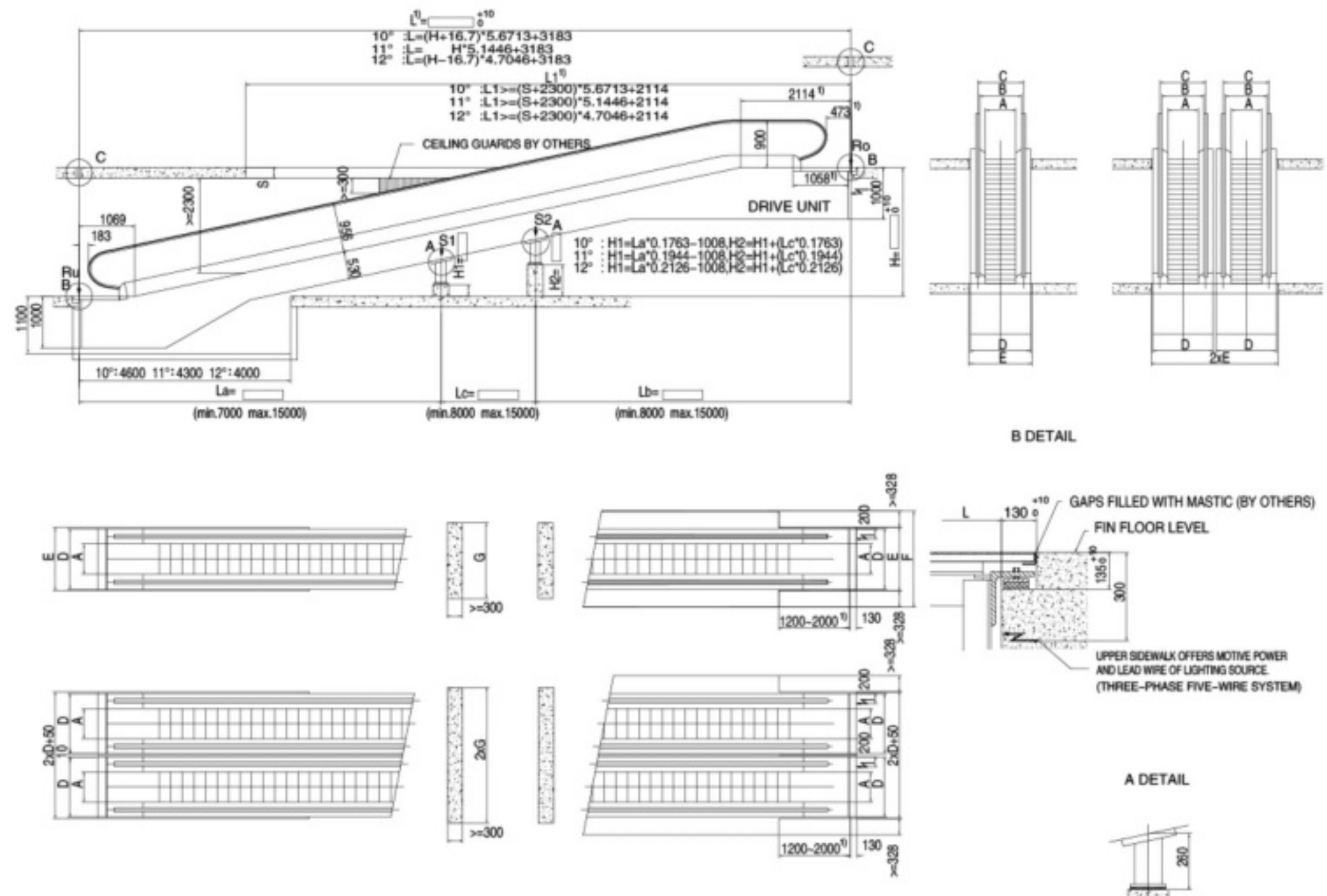

Support					
Without mid-support	Single mid-support		Double mid-supports		
$R_o = L \cdot q + M$	$R_o = L_b \cdot q + M$	$R_o = L_b \cdot q + M$			
	$R_u = L_a \cdot q + N$	$R_u = L_a \cdot q + N$			
$R_u = L \cdot q + N$	$S_1 = (L_a + L_b) \cdot q \cdot 1.3$		$S_1 = (L_a + L_c) \cdot q \cdot 1.3$		
			$S_2 = (L_b + L_c) \cdot q \cdot 1.3$		

Supported by force	q	M	N
YSS80	0.0039	9.5	4.5
YSS100	0.0045	11	5

	YSS80	YSS100
A	800	1000
B	957	1157
C	1037	1237
D	1340	1540
E	1380	1580
F	2036	2236
G	1300	1500

1. Use the tread with 266mm pitch.
2. Upper truss shall increase 417mm for double-drive.
3. Detailed motor power parameters may check with our technical department.

Tilt angle	Rise		Mid-support		La	Lb	Lc
	Min	Max	S1	S2			
10°	1273	2154	-	-	-	-	-
	2155	3388	1	-	7000	L-7000	-
	3389	4799	1	-	L-15000	15000	-
	4800	6000	1	1	7000	15000	L-22000
11°	1423	2394	-	-	-	-	-
	2395	3754	1	-	7000	L-7000	-
	3755	5309	1	-	L-15000	15000	-
	5310	6000	1	1	7000	15000	L-22000
12°	1572	2634	-	-	-	-	-
	2635	4122	1	-	7000	L-7000	-
	4123	5822	1	-	L-15000	15000	-
	5823	6000	1	1	7000	15000	L-22000

HS300-III Double-Arc Moving Walk Construction Layout drawing (10° ~ 12°)

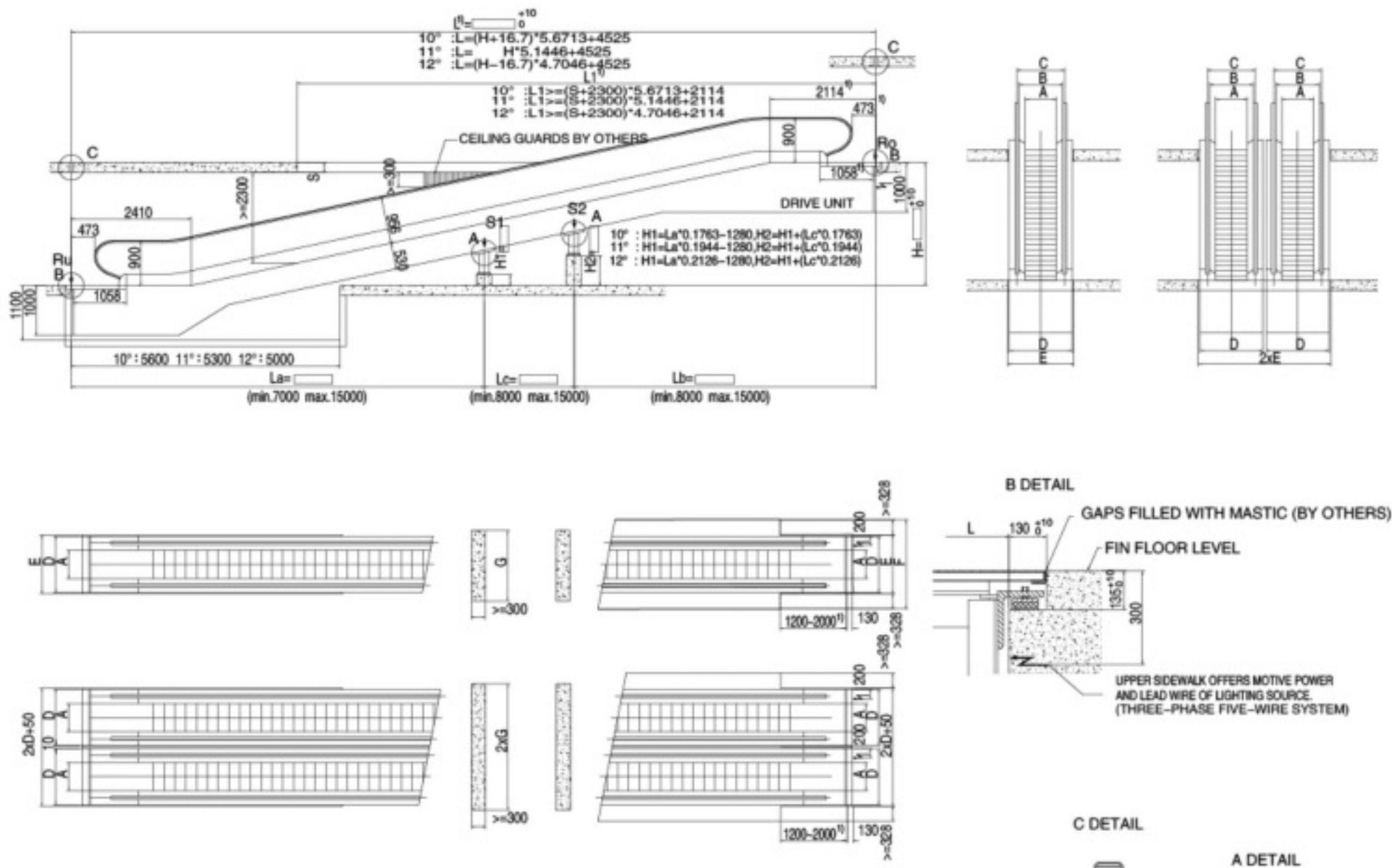

Support		
Without mid-support	Single mid-support	Double mid-supports
$R_o = L \cdot q + M$	$R_o = L_b \cdot q + M$ $R_u = L_a \cdot q + N$	$R_o = L_b \cdot q + M$ $R_u = L_a \cdot q + N$
$R_u = L \cdot q + N$	$S_1 = (L_a + L_b) \cdot q \cdot 1.3$	$S_1 = (L_a + L_c) \cdot q \cdot 1.3$ $S_2 = (L_b + L_c) \cdot q \cdot 1.3$

Supported by force	q	M	N
YSS80	0.0039	9.5	4.5
YSS100	0.0045	11	5

	YSS80	YSS100
A	800	1000
B	957	1157
C	1037	1237
D	1340	1540
E	1380	1580
F	2036	2236
G	1300	1500

- Upper truss shall increase 417mm for double-drive.
- Detailed motor power parameters may check with our technical department.

Tilt angle	Rise		Mid-support		La	Lb	Lc
	Min	Max	S1	S2			
10°	1273	2154	-	-	-	-	-
	2155	3388	1	-	7000	L-7000	-
	3389	4799	1	-	L-15000	15000	-
	4800	6000	1	1	7000	15000	L-22000
11°	1423	2394	-	-	-	-	-
	2395	3754	1	-	7000	L-7000	-
	3755	5309	1	-	L-15000	15000	-
	5310	6000	1	1	7000	15000	L-22000
12°	1572	2634	-	-	-	-	-
	2635	4122	1	-	7000	L-7000	-
	4123	5822	1	-	L-15000	15000	-
	5823	6000	1	1	7000	15000	L-22000

HS300 Moving Walk Construction Layout drawing (0°)

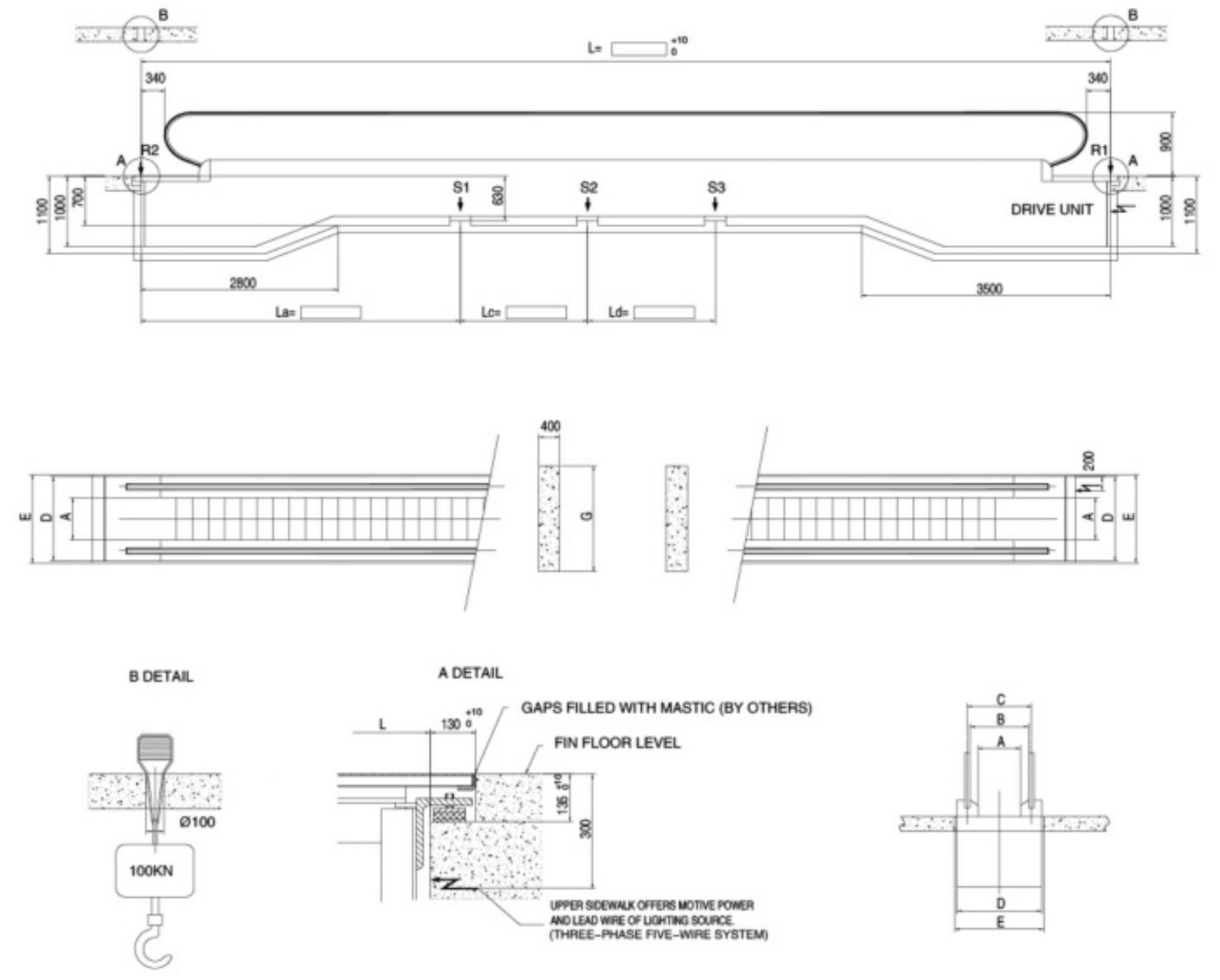

	YSH80	YSH100
A	800	1000
B	957	1157
C	1037	1237
D	1340	1540
E	1380	1580
F	2036	2236
G	1300	1500

Escalator/Moving Walk installation notice

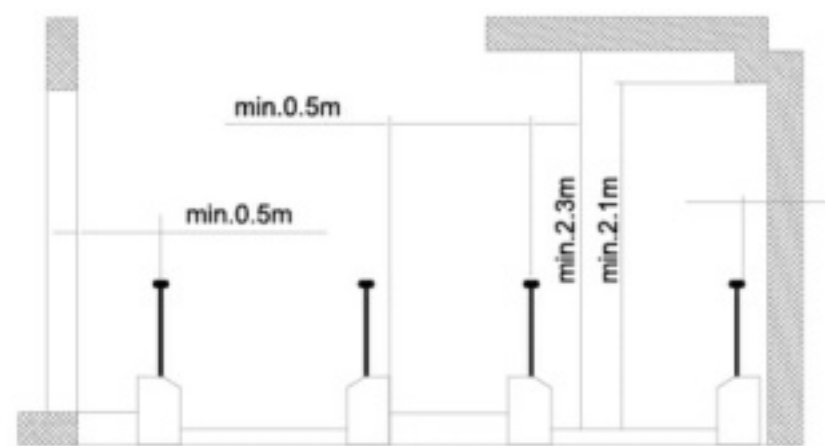
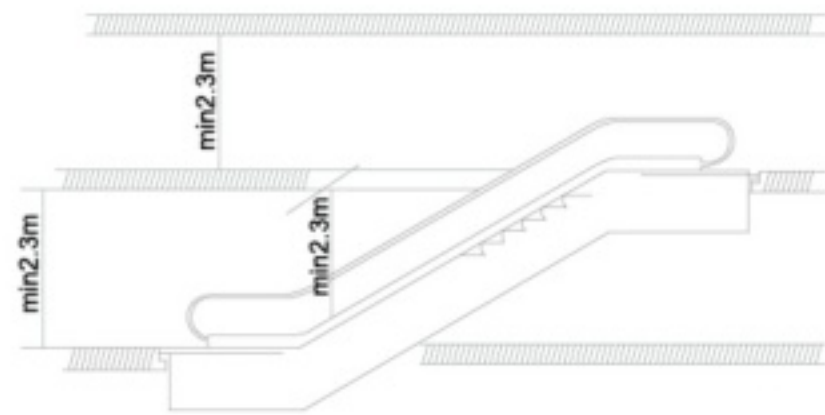
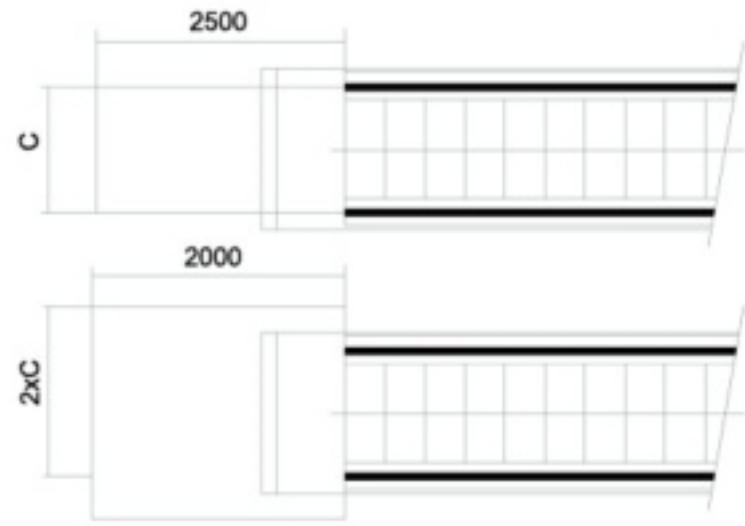

Besides complying with the drawing of the contract, attention should also be drawn to the following

- To ensure the safety of the escalator and Moving walk, free space should be large enough in the landing area. (See the minimum size left)
- C= the distance of the handrails

Vertical safety distance

- There should be at least 2.3m upside safety distance starting upward from the step board.
- Notice: if the vertical rise of one escalator, which is installed above another one, is less than 3.3m, the upside safety distance can not reach 2.3m.

Escalators and Moving walk horizontal safety distance

- The horizontal distance between the handrail edge and the wall or other objects should be more than 80mm.
- The vertical distance above the step board should be more than 2.3m.
- The vertical distance above the handrail space should be more than 2.1m.
- In case of floor spaces or the cross layout of escalators and Moving walk, the safety distance between the handrail center and the object should be more than 0.5m.
- If the above-mentioned requirements cannot be met, a special protection device and a bumper rail should be used.
- For further information, please contact Hanson Elevator.

